

DETAIL A
SCALE 4 : 1

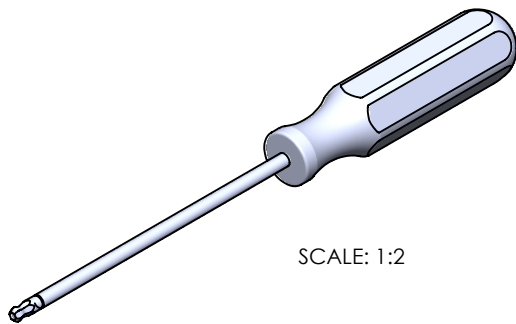
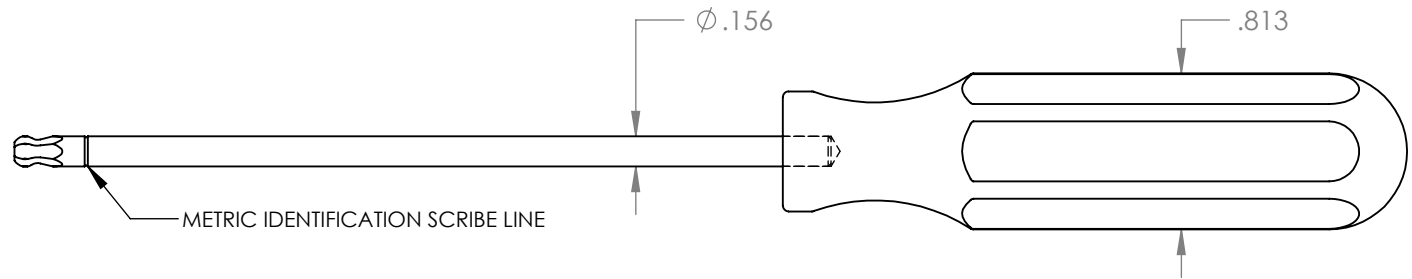

SCALE: 1:2

| | | | | | |
|---|------|------|---|--------------|---|
| UNLESS OTHERWISE SPECIFIED: DIMENSIONS ARE IN INCHES | | | TOLERANCES: X.XX= ±0.13 X.XXX= ±0.015 X.XXXX= -0.002 | | |
| DRAWN | NAME | SIGN | DATE | | |
| APP'VD | A.T. | | 06.10.19 | | TITLE: 3.5MM BALL DRIVER with STAINLESS STEEL HANDLE |
| MATERIAL: SHAFT: 465 MAGNETIC S.S. HANDLE: 316 NON-MAGNETIC S.S. | | | | | PART NO. 21824 |
| <i>THIS DRAWING IS THE PROPERTY OF STERITOOL, INC. ANY REPRODUCTIONS OR MODIFICATIONS OF THIS DRAWING OR ITS CONTENTS WITHOUT THE CONSENT OF STERITOOL, INC. IS PROHIBITED.</i> | | | | | REV: A |
| | | | SCALE: 1:1 | SHEET 1 OF 1 | |